



micro|waterjet®

SPEEDING TICKET

January 2017

Micro Waterjet vs. Wire EDM

Microwaterjet® has many advantages over competitive processing methods.

Depending on the process, Microwaterjet® cutting can show very significant savings in time as well as maintaining the integrity and quality of the piece being cut.

We performed a side-by-side comparison of the Microwaterjet® and Wire EDM. The part cut is complex.

The following example is for the processing of this Copper Electrode.

Specifications:

Name: Copper Electrode
Material: Copper, non-ferrous
Material thickness: 1 mm

In addition to saving time processing each part, Microwaterjet® maintains the integrity of the part since it cuts without Heat Affected Zones (HAZ). This presents opportunities to cut materials with little to no biocompatibility issues or deburring. It is also possible to stack cut on the Microwaterjet® although some tapering may occur depending on the material/thickness and speed of the cut.

Processing time for Microwaterjet® vs. Wire EDM.



As you can see, the savings in machining time for Microwaterjet® compared to Wire EDM is significant.

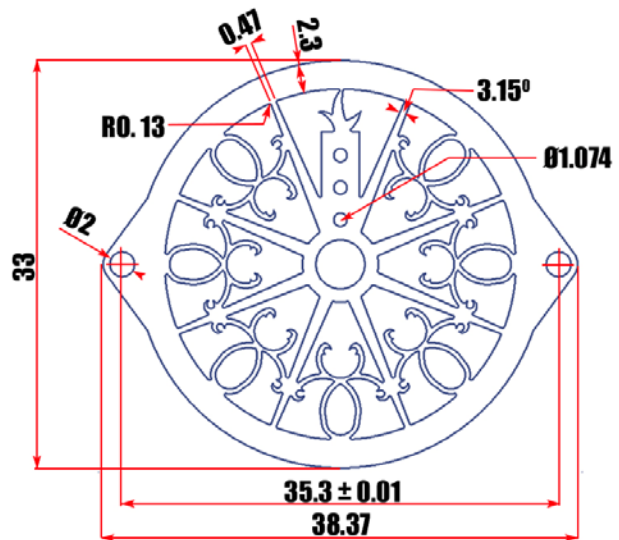

All Dimensions are in Millimeters

To discuss how Micro Waterjet can help you achieve outstanding results with your precision parts, please contact us today!

Steve Parette
Managing Director

Tel: (704) 948-1213
Fax: (704) 948-1251
sparette@microwaterjet.com

Brian Pitts
Technical Sales Engineer

Tel: (704) 948-1218
Fax: (704) 948-1252
bpitts@microwaterjet.com

Micro Waterjet, LLC • 13420 Reese Blvd West • Huntersville, NC 28078
Tel: 704-948-1223 • Fax: 704-875-0781 • Email: info@microwaterjet.com

www.microwaterjet.com

Fluid Precision. Flawless Results.

